

## auto electrical parts

### Technical Information Sheet

#### Part No. 0-445-76

Mini LED beacon, 12-110 volt dc with polycarbonate amber lens and magnetic base, 45 quad flashes per minute, 5 high intensity LED's. Ø72 x h 130mm. CE approved.

#### Additional information

The beacon is supplied with retractable cable and cigarette plug (2.45m working length)



#### Technical Drawing (not to scale)

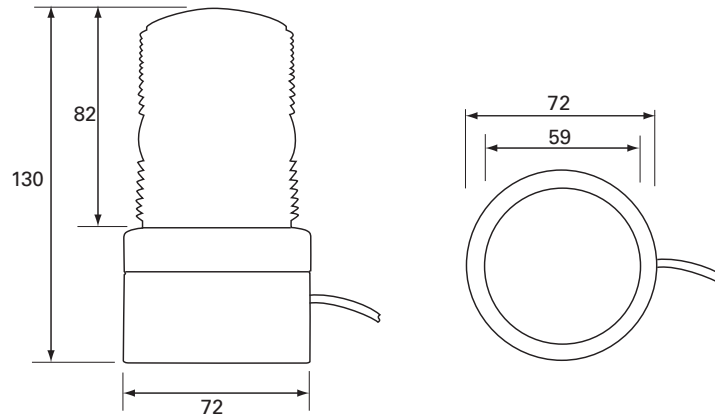

#### Specification

Type	LED beacon
Voltage rating	12 - 110 volt dc
Current	0.35 amp
LED	5 x 1 watt
Flash rate	45 per minuite
Lens	Polycarbonate
Weight	430g
Dimensions	Ø72 x h 130mm
Compliance	CE
Protection	IP65

The information contained in this document is correct to the best of our knowledge at the time of printing. However, specifications may change at any time without notice.